

Floating Scum Skimmers

FSP

Matchless!!

As the FSP-series is a floating type scum skimmer, it can meet any water level and effectively remove scum. A proprietary jet-injector mechanism ensures stable suction.



CONTACT US:

GUDANG MULTIGUNA ALAM SUTERA
T8 NO. 35 ALAM SUTERA
SERPONG-TANGERANG SELATAN
TELP. (021) 29047345 (HUNTING)
FAX. (021) 29047346
EMAIL: dselaras@yahoo.com



PT. DWIJAYA SELARAS



TSURUMI PUMP

Jet-injector FSP

A new suggestion for scum skimming

It efficiently removes more scum and less supernatant liquid than conventional equivalents.

- ① As it is a floating type, a suction mouth can keep its relative position with the water surface. This prevents operation failure due to changes in the water level.
- ② The suction mouth can be adjusted to a depth between 0 to 60 millimeters, it can efficiently suck scum with minimal amount of water.
- ③ A jet-injector mechanism prompts suction operation and helps it suck stably even if water, air and scum are drawn simultaneously.
- ④ Use of a flexible hose simplifies installation.

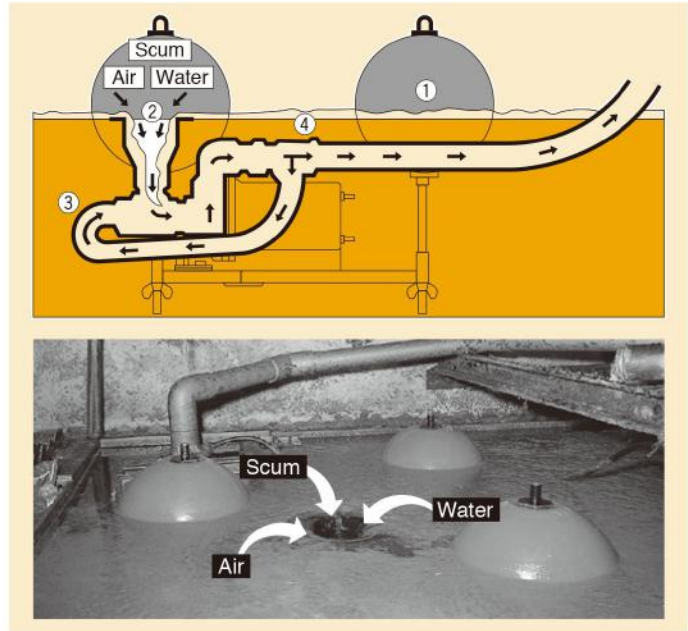

Application

Removal of suspended matters on water surface

Standard Accessories

Hose Coupling.....1pc.
Mooring Rope (6m).....3pcs.

Performance Curves

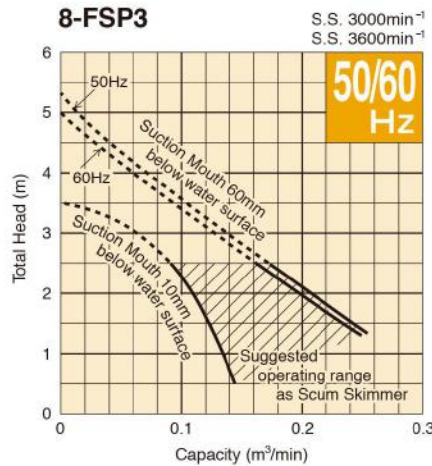
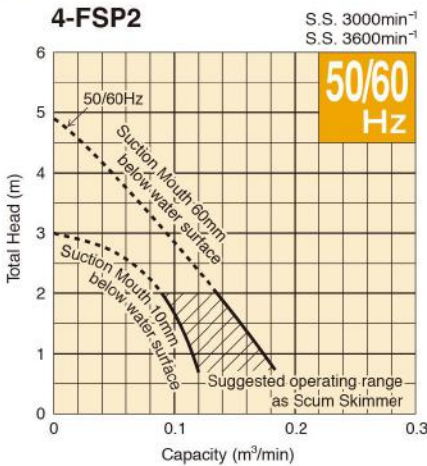

Dimensions

Unit: mm

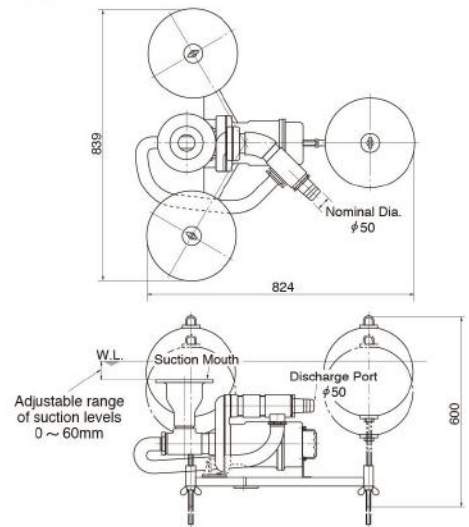

Model Selection 50/60Hz

Discharge Bore mm	Model	Motor Output kW	Phase	Speed (S.S.) min ⁻¹	Starting Method	Solids Passage mm	Dry Weight kg	Cable Length m
50	4-FSP2	0.4	Three	3000/3600	D.O.L.	16	36	6
50	8-FSP3	0.75	Three	3000/3600	D.O.L.	22	38	6

● Weights excluding cable

CONTACT US:

GUDANG MULTIGUNA ALAM SUTERA
T8 NO. 35 ALAM SUTERA
SERPONG-TANGERANG SELATAN
TELP. (021) 29047345 (HUNTING)
FAX. (021) 29047346
EMAIL: dselaras@yahoo.com



PT. DWIJAYA SELARAS



TSURUMI PUMP